

# DINION IP dynamic 7000 HD

www.boschsecurity.com



**BOSCH**  
Invented for life



HD ONVIF



- ▶ High Dynamic Range to see details in bright and dark areas simultaneously (106 dB with iAE)
- ▶ Intelligent noise reduction reduces bandwidth and storage requirements by up to 30%
- ▶ Auto back focus for fast installation
- ▶ Content-based scene analysis optimizes the image processing
- ▶ Hybrid operation for easy migration from analog to IP systems

The DINION IP dynamic 7000 HD camera is a 1080p30 progressive scan CMOS camera that uses Bosch-designed digital imaging technology to achieve a very high dynamic range.

The camera uses an internal feedback system based on the intelligent analysis of the scene, to re-tune the video processing. This provides better detail in the areas that matter and better all-round performance, day or night. Features such as multicasting, internet streaming and iSCSI recording are fully supported.

## System overview

### High Dynamic Range

The High Dynamic Range (HDR) of the camera means that you can view details in the bright and the dark areas of a scene at the same time. HDR is based on a dual exposure process that captures more details in highlights and shadows even under challenging lighting conditions. The result is that you can distinguish objects and features easily.

### Hybrid operation

A surge-protected analog video output allows full hybrid operation. This means that high resolution IP video streaming and an analog video output via an

SMB connector are available simultaneously. The hybrid functionality offers an easy migration path from legacy CCTV to a modern IP-based system.

## Functions

### Content-Based Imaging Technology

Content-Based Imaging Technology (C-BIT) is used to radically improve image quality in all lighting conditions and to identify areas for enhanced processing. The camera examines the scene using intelligent video analytics and provides feedback to re-tune the image processing. This provides better detail in the areas that matter and better all-round performance. With IVA, the intelligent Automatic Exposure (iAE) technology, for example, allows you to view moving objects in bright and dark areas of a scene.

### iDNR reduces bandwidth and storage requirements

The camera uses intelligent Dynamic Noise Reduction (iDNR) which actively analyzes the contents of a scene and reduces noise artifacts accordingly. The low-noise image and the efficient H.264 compression technology provide clear images while reducing bandwidth and storage by up to 30% compared to other H.264 cameras. This results in reduced-bandwidth streams that still retain a high

image quality and smooth motion. The camera provides the most usable image possible by cleverly optimizing the detail-to-bandwidth ratio. Area-based encoding is another feature which reduces bandwidth. Compression parameters for up to eight user-definable regions can be set. This allows uninteresting regions to be highly compressed, leaving more bandwidth for important parts of the scene. The average typical optimized bandwidth in kbits/s for various image rates is shown in the table:

IPS	1080p	720p	480p
30	1600	1200	600
15	1274	955	478
12	1169	877	438
5	757	568	284
2	326	245	122

### Multiple streams

The innovative multi-streaming feature delivers various H.264 streams together with an M-JPEG stream. These streams facilitate bandwidth-efficient viewing and recording as well as integration with third-party video management systems.

An upright mode can be selected for the second stream. In this mode an image of 400 x 720 (9:16 aspect ratio) is cropped from the full sensor image. When the scene to be monitored is suitable to this mode, the bandwidth and storage requirements are reduced.

### Regions of interest and E-PTZ

Regions of Interest (ROI) can be user defined. The remote E-PTZ (Electronic Pan, Tilt and Zoom) controls allow you to select specific areas of the parent image. These regions produce separate streams for remote viewing and recording. These streams, together with the main stream, allow the operator to separately monitor the most interesting part of a scene while still retaining situational awareness.

With IVA, the Intelligent tracker can follow objects within the defined regions of interest. The Intelligent tracker can autonomously detect and track moving objects or the user can click on an object which the Intelligent tracker will then follow.

### Simple set-up

The camera has a very intuitive user interface that allows fast and easy configuration. Six configurable user modes are provided with the best settings for a variety of applications:

- **Indoor** – general day-to-night changes without sun highlights and street lighting
- **Outdoor** – general day-to-night changes with sun highlights and street lighting
- **Motion** – monitoring traffic or fast moving objects; motion artifacts are minimized
- **Lowlight** – optimized for sufficient details at low light.

- **Intelligent AE** – for people moving in front of a bright background
- **Vibrant** – enhanced contrast, sharpness and saturation

### Storage management

Recording management can be controlled by the Bosch Video Recording Manager (VRM) or the camera can use iSCSI targets directly without any recording software.

### Video analytics

With built-in video content analysis, the camera reinforces the Intelligence-at-the-Edge concept where edge devices become increasingly intelligent. The MOTION+ video motion analysis system that is built into all camera versions is the perfect solution for applications where standard video content analysis features are required.

The IVA version of the camera uses the latest generation of the Bosch Intelligent Video Analysis (IVA) software. This IVA system is the guard-assistant system of choice when reliable indoor or outdoor video analytics is needed. The state-of-the-art system reliably detects, tracks, and analyzes moving objects while suppressing unwanted alarms from spurious sources in the image.

The face detection feature detects faces in the scene and forwards a high quality JPEG image of the best shot of each face when the face disappears from the scene.

Retrospective forensic search capabilities are available remotely from the web browser or the Bosch Video Client.

### Cloud-based services

The camera supports time-based or alarm-based JPEG posting to four different accounts. These accounts can address FTP servers or cloud-based storage facilities (for example, Dropbox). Video clips or JPEG images can also be exported to these accounts.

Alarms can be set up to trigger an e-mail or SMS notification so you are always aware of abnormal events.

### Access security

Password protection with three levels and 802.1x authentication is supported. To secure Web browser access, use HTTPS with a SSL certificate stored in the camera. The video and audio communication channels can be independently AES encrypted with 128-bit keys by installing the optional encryption site license.

### Complete viewing software

There are many ways to access the camera's features: using a web browser, with the Bosch Video Management System, with the Bosch Recording System, with the free-of-charge Bosch Video Client, or with the video security mobile App.

The Bosch Video Client PC surveillance software offers a user-friendly interface to support easy installation and configuration. It also provides easy live viewing of multiple cameras, playback, forensic search and export.

### Video security App

The Bosch video security mobile App has been developed to enable **Anywhere** access to HD surveillance images allowing you to view live images from any location. The App is designed to give you complete control of all your cameras, from panning and tilting to zoom and focus functions. It's like taking your control room with you.

This App, together with the separately available Bosch transcoder, will allow you to fully utilize our dynamic transcoding features so you can play back images even over low-bandwidth connections.

### System integration

The camera conforms to the ONVIF (Open Network Video Interface Forum) Profile S specification. This guarantees interoperability between network video products regardless of manufacturer. For trouble-free network cabling, the camera supports Auto-MDIX which allows the use of straight or cross-over cables. Third-party integrators can easily access the internal feature set of the camera for integration into large projects. Visit the Bosch Integration Partner Program (IPP) website ([ipp.boschsecurity.com](http://ipp.boschsecurity.com)) for more information.

### True day/night switching

The camera incorporates mechanical filter technology for vivid daytime color and exceptional night-time imaging while maintaining sharp focus under all lighting conditions.

### Easy installation

Power for the camera can be supplied via a Power-over-Ethernet compliant network cable connection. With this configuration, only a single cable connection is required to view, power, and control the camera. Using PoE makes installation easier and more cost-effective, as cameras do not require a local power source.

The camera can also be supplied with power from +12 VDC/24 VAC power supplies. To increase system reliability, the camera can be simultaneously connected to both PoE and +12 VDC/24 VAC supplies. Additionally, uninterruptible power supplies (UPS) can be used, which will allow continuous operation, even during a power failure.

The auto-focus lens wizard makes it easy for an installer to accurately focus the camera for both day and night operation. The wizard is activated from the web browser or from the on-board camera push button making it easy to choose the workflow that suits best. The automatic motorized back focus adjustment with 1:1 pixel mapping ensures the camera is always focused accurately.

### Typical applications

- Tunnels – viewing details in bright and dark areas
- Entrances and exits – identification with strong backlight
- Traffic – capturing moving vehicles at night

### Certifications and approvals

#### HD standards

Complies with the SMPTE 274M-2008 Standard in:

- Resolution: 1920x1080
- Scan: Progressive
- Color representation: complies with ITU-R BT.709
- Aspect ratio: 16:9
- Frame rate: 25 and 30 frames/s

Complies with the 296M-2001 Standard in:

- Resolution: 1280x720
- Scan: Progressive
- Color representation: complies with ITU-R BT.709
- Aspect ratio: 16:9
- Frame rate: 25 and 30 frames/s

Standards	
Emission	EN55022 Class B FCC Part 15, class B
Immunity	EN50130-4 (PoE, +12 VDC, 24 VAC)* EN50121-4
Safety	EN60950-1 UL60950-1 (2nd edition) CAN/CSA-C 22.2 No. 60950-1
Vibration	Camera with lens as per IEC60068-2-6 (5 m/s <sup>2</sup> , operational)
ONVIF conformance	EN 50132-5-2; IEC 62676-2-3

\* Chapters 7 and 8 (mains voltage supply requirement) are not applicable to the camera. However, if the system in which this camera is used needs to comply with this standard, then any power supplies used must comply with this standard.

Region	Certification
Europe	CE
USA	UL
Canada	ULC

## Installation/configuration notes

### Controls

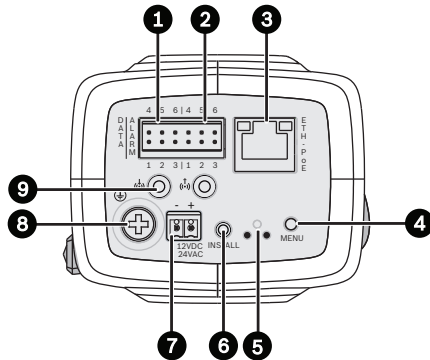

1	Data (RS485/422/232)	6	Video out
2	Alarm in, alarm out	7	Power supply input
3	10/100 Base-T Fast Ethernet	8	Earth
4	Menu button	9	Audio in / Audio out
5	Reset button		

### Dimensions

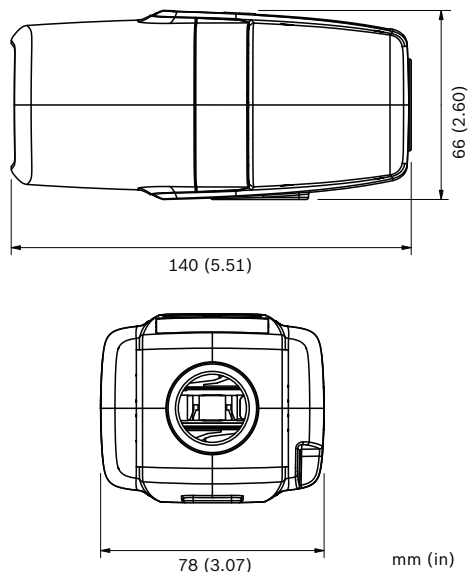

## Technical specifications

Power	
Power Supply	24 VAC 50/60 Hz 12 VDC Power-over-Ethernet 48 VDC nominal
Current Consumption	500 mA (12 VDC) 450 mA (24 VAC) 175 mA (PoE 48 VDC)
Power Consumption	6 W (12 VDC)

Power	
	10.8 W (24 VAC) 8.4 W (PoE 48 VDC)
PoE	IEEE 802.3af (802.3at Type 1)

Sensor	
Type	1/3-inch CMOS
Pixels	2048 x 1536 (3MP)

Video performance	
Sensitivity – (3200K, reflectivity 89%, F1.2, 30IRE)	
• Color	0.25 lx (0.025 fc)
• Mono	0.08 lx (0.008 fc)
Dynamic range	90 dB High Dynamic Range (HDR) 106 dB HDR (with iAE)

Video streaming	
Video compression	H.264 (MP); M-JPEG
Streaming	Multiple configurable streams in H.264 and M-JPEG, configurable frame rate and bandwidth. Regions of Interest (ROI)
Overall IP Delay	Min. 120 ms, Max. 240 ms
GOP structure	IP, IBP, IBBP
Encoding interval	1 to 30 (25) ips

Resolutions (H x V)	
• 1080p HD	1920 x 1080
• 960p HD 4:3 (cropped)	1280 x 960
• 720p HD	1280 x 720
• Upright 9:16 (cropped)	400 x 720
• D1 4:3 (cropped)	704 x 480
• 480p SD	Encoding: 704 x 480; Displayed: 854 x 480
• 432p SD	768 x 432
• 288p SD	512 x 288
• 240p SD	Encoding: 352 x 240; Displayed: 432 x 240
• 144p SD	256 x 144

Video functions	
Day/Night	Color, Mono, Auto
White Balance	ATW (2500 to 10000K), ATWhold and manual

Video functions	
Shutter	Automatic Electronic Shutter (AES) Fixed (1/30 [1/25] to 1/15000) selectable Default shutter
High dynamic range	On/off
Backlight compensation	Off / On / iAE
Contrast enhancement	On/off
Noise reduction	Intelligent Dynamic Noise Reduction (iDNR) with separate temporal and spatial adjustments
Sharpness	Sharpness enhancement level selectable
Privacy Masking	Four independent areas, fully programmable
Video Motion Analysis	Intelligent Video Analysis (IVA)

Audio streaming	
Audio Streaming	Full duplex / half duplex
Signal-to-noise ratio	> 50 dB
Audio compression	AAC-LC, G.711, L16 (live and recording)

Input/output	
Analog video out	CVBS (PAL/NTSC), 1 Vpp, SMB, 75 Ohm (surge protected)
Analog video aspect ratio	4:3 letterbox, 4:3 cropped, or 16:9 mode
Audio	1 x mono line in, 1 x mono line out
• connector	3.5 mm stereo jack
• signal line in	12 kOhm typical, 1 Vrms max
• signal line out	1 Vrms at 1.5 kOhm typical,
Alarm	2 inputs
• connector	Clamp (non-isolated closing contact)
• activation voltage	+5 VDC to +40 VDC (+3.3 VDC with DC-coupled 22 kOhm pull-up resistor)
Relay	1 output
• connector	Clamp
• voltage	30 VAC or +40 VDC Maximum 0.5 A continuous, 10VA
Data port	RS-232/422/485

Network	
Protocols	IPv4, IPv6, UDP, TCP, HTTP, HTTPS, RTP/ RTCP, IGMP V2/V3, ICMP, ICMPv6, RTSP, FTP, Telnet, ARP, DHCP, SNTP, SNMP (V1,

Network	
	MIB-II), 802.1x, DNS, DNSv6, DDNS, SMTP, iSCSI, UPnP (SSDP), DiffServ (QoS), LLDP, SOAP, Dropbox, CHAP, Digest Authentication.
Encryption	TLS 1.0, SSL, DES, 3DES, AES (optional)
Ethernet	10/100 Base-T, auto-sensing, half/full duplex
Ethernet connector	RJ45
Connectivity	ONVIF Profile S, Auto-MDIX

Software	
Unit Configuration	Via web browser or Configuration Manager
Firmware update	Remotely programmable
Software viewer	Bosch Video Client

Optical	
Lens mount	CS mount (C-mount with adapter ring)
Lens connector	Standard 4-pin DC-iris connector
Lens Types	Manual and DC-Iris auto-detect with override DC-iris drive: max. 50 mA continuous
Lens Controls	Wizard from web page or camera button

Mechanical	
Dimensions (W x H x L)	78 x 66 x 140 mm (3.07 x 2.6 x 5.52 inch) without lens
Weight	690 g (1.52 lb) without lens
Color	RAL 9007 Metallic Titanium
Tripod Mount	Bottom (isolated) and top 1/4-inch 20 UNC

Environmental	
Operating Temperature	-20°C to +50°C (-4°F to 122°F)
Storage Temperature	-30°C to +70°C (-22°F to +158°F)
Operating Humidity	20% to 93% RH
Storage Humidity	up to 98% RH

### Ordering information

#### DINION IP dynamic 7000 HD

High-performance IP box camera for intelligent HD surveillance. HDR; hybrid IP/Analog; 1080p30; PoE; iDNR; iAE; ROI; day/night; H.264 quad-streaming; free viewing Apps; cloud services; audio/motion detection; IVA  
Order number **NBN-72027-BA**

#### Varifocal SR Megapixel Lens

Rugged varifocal SR megapixel IR corrected lens. 1/2.5" sensor; CS-mount; 4-pin SR-iris; 5 MP; 9 to 40 mm; F1.5 to F8  
Order number **LVF-5005C-S0940**

**Varifocal SR Megapixel Lens**

Rugged varifocal SR megapixel lens. 1/2" sensor; C-mount; 4-pin SR-iris; 3 MP; 3.8 to 13 mm; F1.4 to F8  
Order number **LVF-5003N-S3813**

**Varifocal SR Megapixel Lens**

Rugged varifocal SR megapixel IR corrected lens.  
1/2.5" sensor; CS-mount; 4-pin SR-iris; 5 MP; 1.8 to 3 mm; F1.8 to F8  
Order number **LVF-5005C-S1803**

**UPA-2430-60 Power Supply**

Power supply for camera. 120 VAC, 60 Hz; 24 VAC, 30 VA Out  
Order number **UPA-2430-60**

**UPA-2410-60 Power Supply**

Power supply. 120 VAC, 60 Hz; 24 VAC, 10 VA Out  
Order number **UPA-2410-60**

**VJT-XTCXF**

High-performance video transcoder. H.264; CF card slot; ROI; 2 channels  
Order number **VJT-XTCXF**

**BVIP AES 128 Bit Encryption**

Site licence for BVIP AES 128-bit encryption. Enables encrypted communication between BVIP devices and management stations  
Order number **MVS-FENC-AES**

**Accessories****S1374 Adapter**

Adapter to convert C mount lens to CS mount camera  
Order number **S1374**

**Interface cable SMB 0.3M**

0.3 m (1 ft) analog cable, SMB (female) to BNC (female) to connect camera to coaxial cable.  
Order number **NBN-MCSMB-03M**

**Monitor/DVR Cable SMB 3.0M**

3 m (9 ft) analog cable, SMB (female) to BNC (male) to connect camera to monitor or DVR.  
Order number **NBN-MCSMB-30M**

**Represented by:****Americas:**

Bosch Security Systems, Inc.  
130 Perinton Parkway  
Fairport, New York, 14450, USA  
Phone: +1 800 289 0096  
Fax: +1 585 223 9180  
security.sales@us.bosch.com  
www.boschsecurity.us

**Europe, Middle East, Africa:**

Bosch Security Systems B.V.  
P.O. Box 80002  
5617 BA Eindhoven, The Netherlands  
Phone: + 31 40 2577 284  
Fax: +31 40 2577 330  
emea.securitysystems@bosch.com  
www.boschsecurity.com

**Asia-Pacific:**

Robert Bosch (SEA) Pte Ltd, Security Systems  
11 Bishan Street 21  
Singapore 573943  
Phone: +65 6571 2808  
Fax: +65 6571 2699  
apr.securitysystems@bosch.com  
www.boschsecurity.asia

**China:**

Bosch (Shanghai) Security Systems Ltd.  
201 Building, No. 333 Fuquan Road  
North IBP  
Changning District, Shanghai  
200335 China  
Phone +86 21 22181111  
Fax: +86 21 22182398  
www.boschsecurity.com.cn

**America Latina:**

Robert Bosch Ltda Security Systems Division  
Via Anhanguera, Km 98  
CEP 13065-900  
Campinas, Sao Paulo, Brazil  
Phone: +55 19 2103 2860  
Fax: +55 19 2103 2862  
latam.boschsecurity@bosch.com  
www.boschsecurity.com